

CREATING POWER SOLUTIONS.

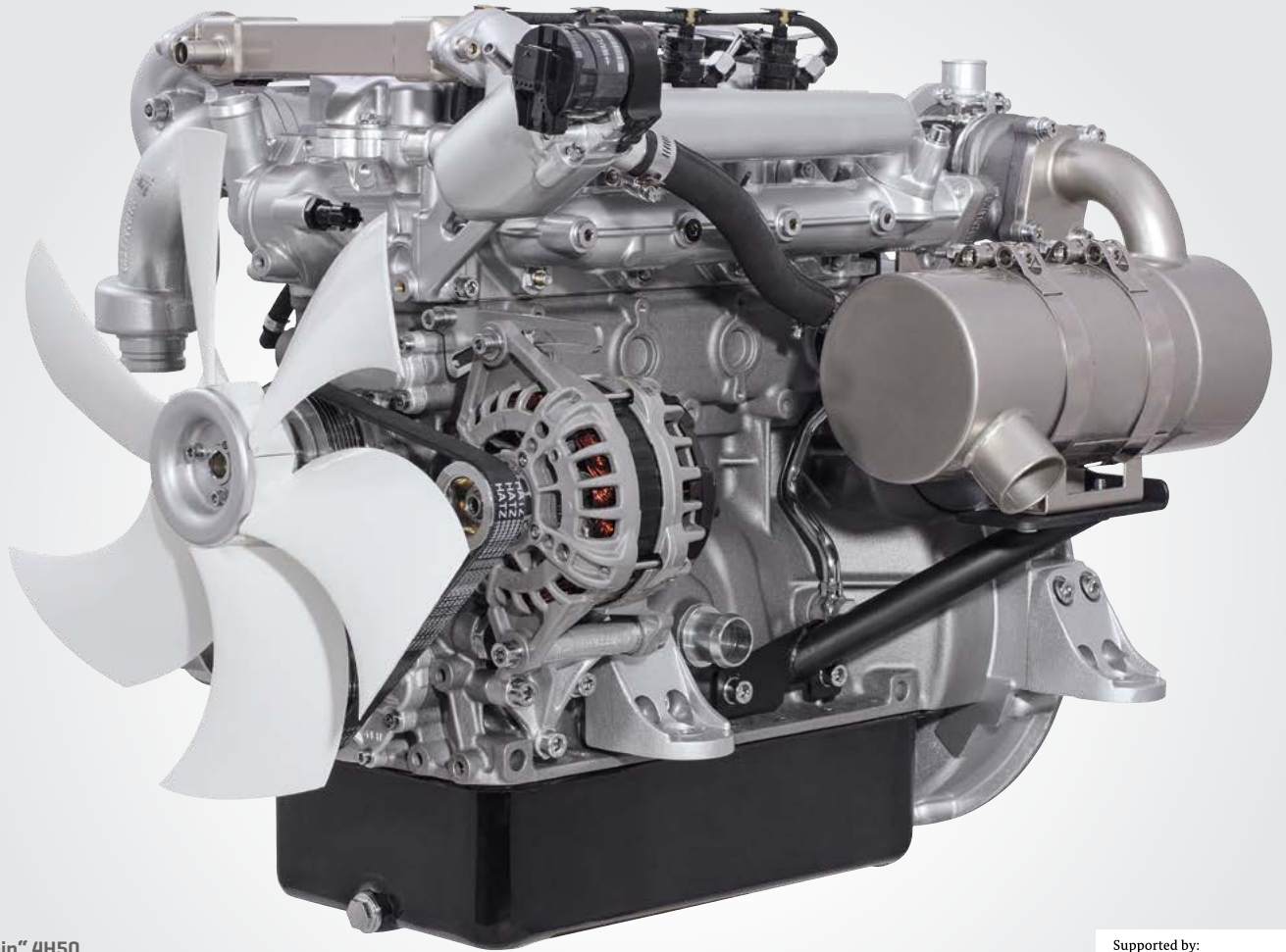

4H50TIC DPF
4H50TIC
4H50TI

Hatz Diesel



„Flag ship“ 4H50

Compact, light, economical, robust and environmentally friendly: The new Hatz common rail diesel engine provides everything expected from a powerful and modern industrial engine. It impresses through its quiet running, dynamics and maintenance friendliness. Its constantly low fuel consumption over a wide load range sets the benchmark.

Supported by:



Federal Ministry
for Economic Affairs
and Energy

on the basis of a decision
by the German Bundestag



Premium components for a premium product

Only high quality parts are used in the 4H50. These include an injection system and sensor system from BOSCH and many other parts from well-known manufacturers.



Open Power Unit – the plug & play solution

All variants of the 4H50 are available as a ready-to-install OPU (Open Power Unit). In addition to the standard scope of delivery, air filter, radiators, charged air radiators, hosing and cable loom are pre-installed at the factory.

H series

Innovation meets reliability

A groundbreaking downsizing approach was adopted in the development of the 4H50. The outcome is an extremely compact, turbocharged 2-litre engine that reaches a maximum power output of 62 kW, setting the benchmark in its performance class with its low weight. The engine fulfills the stringent exhaust emission limits in the EU and the USA even without the use of a diesel particulate filter (DPF).

Conservative-innovative engine for a long service life

All mechanical components were designed and developed with a conservative-innovative approach. The 4H50 therefore has two valves per cylinder, which achieves high efficiency, mechanical robustness and functional simplicity. This – as well as the exclusive use of premium products for all important components – leads to the long service life customary from Hatz.

Maintenance-friendly

The 4H50 also scores highly in terms of user friendliness. Firstly, all maintenance points are accessible on one side of the motor; secondly, the maintenance intervals of 500 engine hours are largely spaced. The extended intervals are attributed to hydraulic valve play compensation and generously sized filters.

Environmental aspects

The 4H50 is 90 kg lighter compared to its nearest competitor. This weight saving ensures a low power/weight ratio and reduced use of raw materials. The engine meets all specifications of legislature in the EU and the USA, even without the use of a particle filter. However, in emission-sensitive conurbations, for example,

a particle filter can be optionally fitted based on local regulations.

BOSCH common rail system

One of the key factors for the high efficiency of the 4H50 is the common rail system. Hatz has decided upon the off highway CRS from Bosch with 1800 bar. It works with up to three precisely dosed injections per working cycle: pre injection, main injection and post injection. In conjunction with the other ideally matched Bosch system components, the perfect balance between dynamics, quiet combustion noise, low emissions and economy is reached.

Fuel efficiency

When it comes to fuel efficiency, with a specific consumption of just 210 g/kWh the newly developed engine sets new standards for top points. However, the special feature is that consumption economy values close to the optimum are also achieved over a large load and speed range. This makes the 4H50 the most efficient engine in the class of 37 – 56/62 kW.

A key element for the extraordinarily high fuel efficiency is the reduction of internal friction due largely to the conservative design with only a few moving parts. A major contribution to this is made by the 2-valve technology in conjunction with roller tappets as well as the lower camshaft that reduces installation space. In addition, only high-end materials are used for the conrod and bearings.

19 - 37 37 - 56 37 - 75

Sales area (exhaust certificate)	[r.p.m]	4H50TIC DPF		4H50TIC		4H50TI	
Stage	V/C	speed	certificate	speed	certificate	speed	certificate
USA (EPA/CARB)	constant	—	—	1500/1800	Tier 4 final	1500/1800	Tier 4i
	variable	—	—	2300-2800	Tier 4 final	2300-2800	Tier 2
EU 97/68	constant	1500/1800	Stage IIIA	—	—	1500/1800	Stage IIIA
	variable	2300-2800	Stage IIIB	2300-2800	Stage IIIB	2200/2600/ 2300-2800	Stage IIIA Stage II
LVR (Switzerland)	constant	1500/1800	Stage IIIA	—	—	—	—
	variable	2300-2800	Stage IIIB	—	—	—	—
Non-EPA	constant	1500/1800/ 3000	None	1500/1800/ 3000	None	1500/1800/ 3000	None
	variable	2300-2800	None	2300-2800	None	2300-3000	None

Technical data, Performance Table

Technical data		4H50TIC DPF	4H50TIC	4H50TI
Type	Water-cooled 4-cylinder turbo engine with BOSCH common rail OHW, 1800 bar, charge air cooling			
Exhaust emission after-treatment	EGR, DOC, DPF	EGR, DOC	—	
Bore x stroke (mm / inches)	84 x 88 / 3.31 x 3.46			
Displacement (l / cu.in.)	1.952 / 119.12			
Mean piston speed at 3000 rpm (m/s / ft/min)	8.8 / 1.732			
Compression ratio	17,5:1			
Lub. oil consumption, related to full load	max. 0.5 % of fuel consumption			
Oil filling	max (l / US qts)	7.0 / 7.4		
	min (l / US qts)	6.0 / 6.3		
Speed control				
• Lowest idle speed	900 r.p.m.			
• Static speed droop	adjustable (0, 3, 5, 10 %)			
Amount of combustion air at 2800 rpm approx. (kg/h)	319			
Amount of cooling air at 2800 rpm approx. (kg/h)	352			
Mass moment of inertia J (kgm ² / lb.ft ²)	J _{engine} 0.234 / 5.553			
Starter	12 V - 2.2 kW (-25°) — 24 V - 3.0 kW (-32°)			
Alternator charging	14 V - 110 A / 28 V - 60 A			
Battery capacity [max]	12 V - 110 Ah / 450A DIN 24 V - 66 Ah / 300A DIN			
Weight	Weight (kg / lbs.) as Open Power Unit	195 / 430	173 / 381	152 / 335
		277 / 611	255 / 562	234 / 516

*19 - 37 kW **37 - 75 kW

Engine output [max]		4H50TIC DPF	4H50TIC	4H50TI
	[r.p.m.]	kW / HP	kW / HP	kW / HP
Blocked ISO brake horsepower [IFN] for intermittent loading according to ISO 3046-1.	3000	—	—	—* 55.0 / 74.8 **
	2800	55.0 / 74.8	55.0 / 74.8	—* 55.0 / 74.8 **
	2600	54.9 / 74.6	54.9 / 74.6	36.4 / 49.5* 54.9 / 74.6 **
	2300	54.0 / 73.4	54.0 / 73.4	36.3 / 49.4* 54.0 / 73.4 **
	2000	50.3 / 68.4	50.3 / 68.4	36.3 / 49.4* 50.3 / 68.4**
	1800	45.2 / 61.5	45.2 / 61.5	36.3 / 49.4* 45.2 / 61.5 **
	1500	37.1 / 50.4	37.1 / 50.4	36.3 / 49.4* 37.1 / 50.4 **
Blocked ISO brake horsepower [IFNsi] for strong intermittent loading according to ISO 3046-1.	2800	—	—	62.0 / 84.3
	2600	—	—	62.0 / 84.3
	2300	—	—	61.2 / 83.2
	2000	—	—	55.3 / 75.2
	1800	—	—	49.7 / 67.6
	1500	—	—	40.8 / 55.5
Blocked ISO standard power output (no overload permissible) acc. to ISO 3046-1. For constant load [ICFN].	2800	49.5 / 67.3	49.5 / 67.3	49.5 / 67.3
	2600	49.4 / 67.2	49.4 / 67.2	49.4 / 67.2
	2300	48.6 / 66.1	48.6 / 66.1	48.6 / 66.1
	2000	45.2 / 61.5	45.2 / 61.5	45.2 / 61.5
	1800	40.7 / 55.3	40.7 / 55.3	40.7 / 55.3
	1500	33.4 / 45.4	33.4 / 45.4	33.4 / 45.4
Blocked ISO standard power output (no overload permissible) acc. to ISO 3046-1. For constant speed and constant load [ICFN]. - e.g. power generators	3000	50.0 / 68.0	50.0 / 68.0	50.0 / 68.0
	1800	36.4 / 49.5	36.4 / 49.5	36.4 / 49.5
	1500	28.7 / 39.0	28.7 / 39.0	28.7 / 39.0

Power output, torque und fuel consumption

4H50TIC DPF, 4H50TIC, 4H50TI

4H50TI

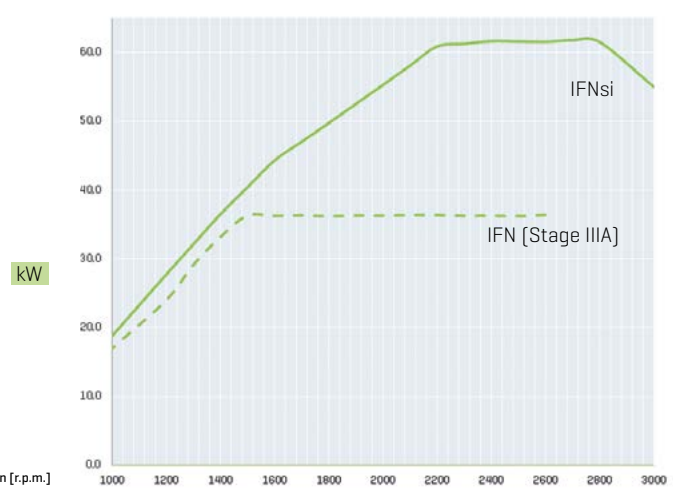
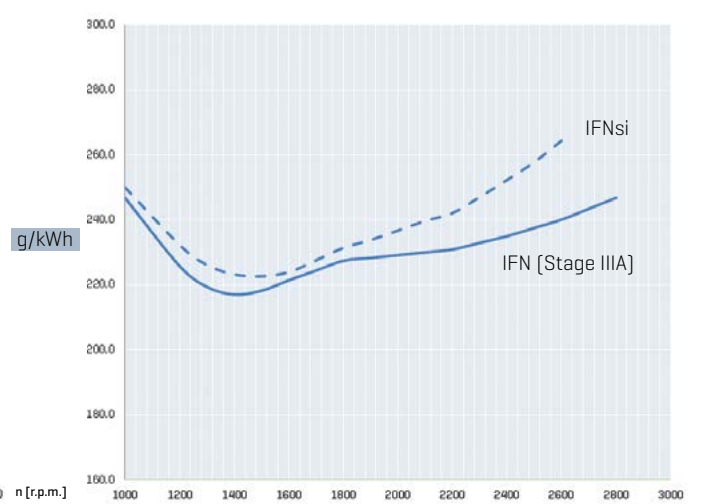
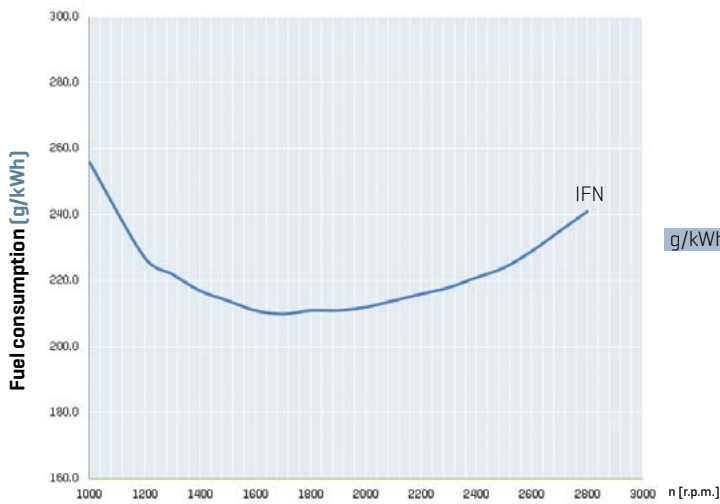
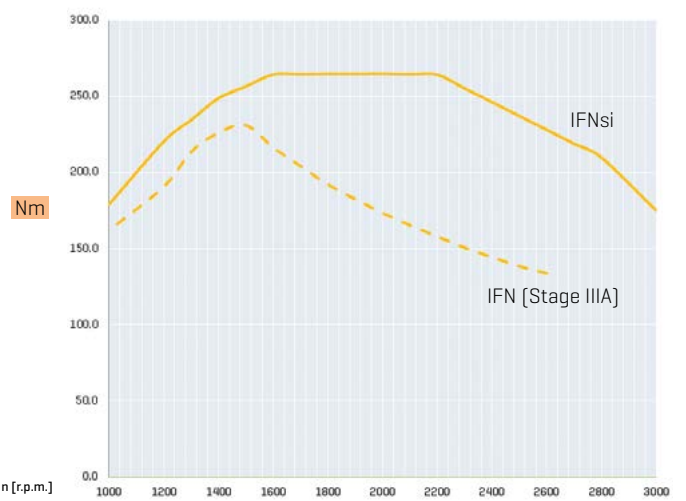
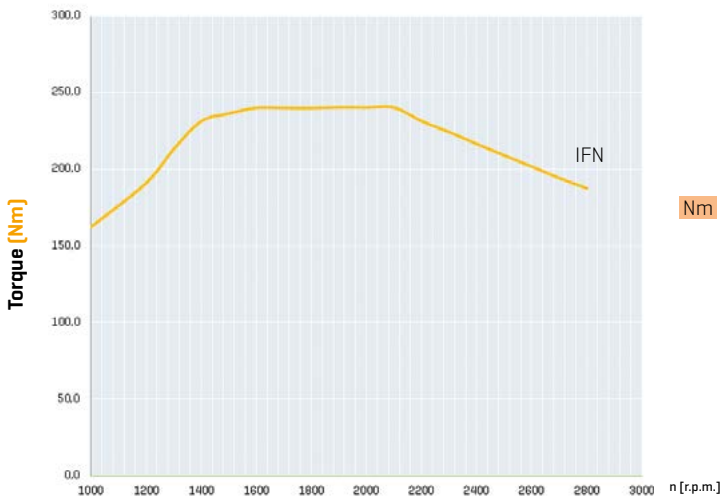

Power ratings

Power reduction chart available on request. Up to 1460 meter no power reduction. Power reduction based on temperature is depending on cooling system, no derating up to +47°C for Hatz OPU.

The power requirement of fan and alternator are already considered in the charts above.

Maintenance and operating points

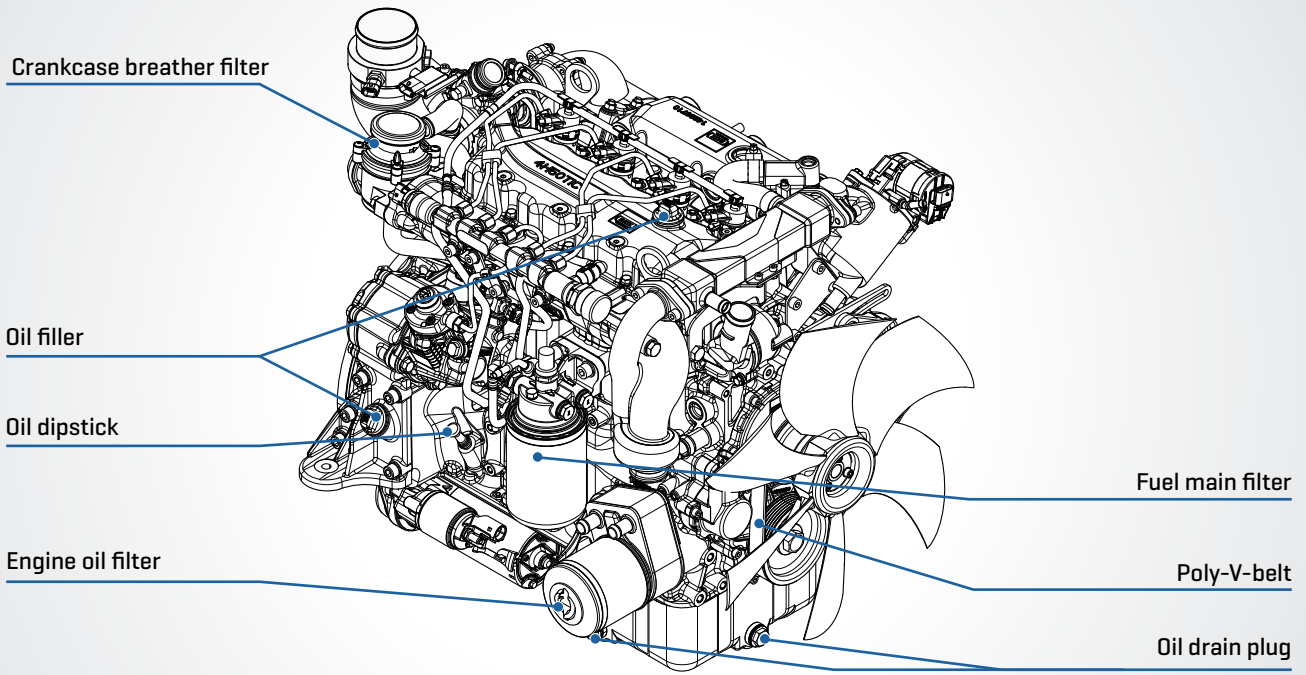

Power take off

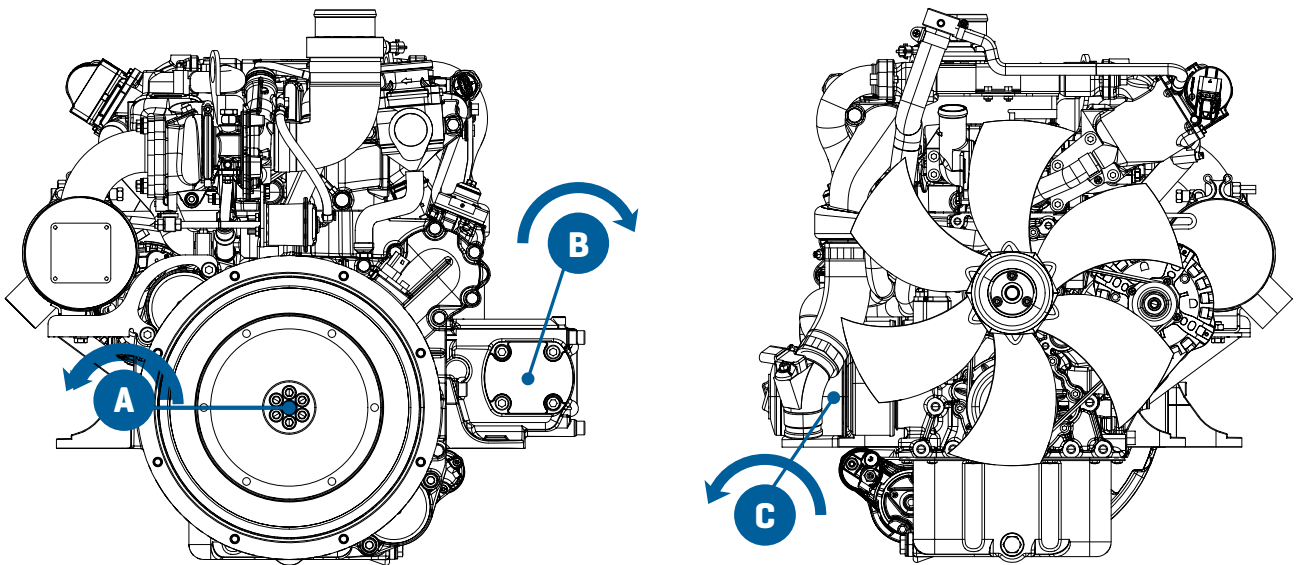

Power take off		4H50TIC DPF	4H50TIC	4H50TI
Transmittable torque	A			100%
	B			$\Sigma = 100 \text{ Nm}; i = 1,1$
	C			

Dimensions

4H50TIC, 4H50TI

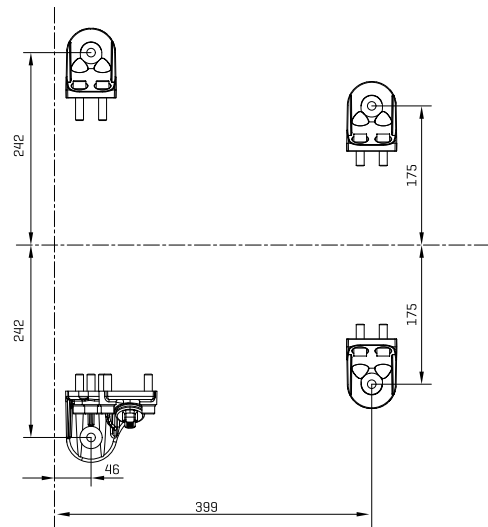
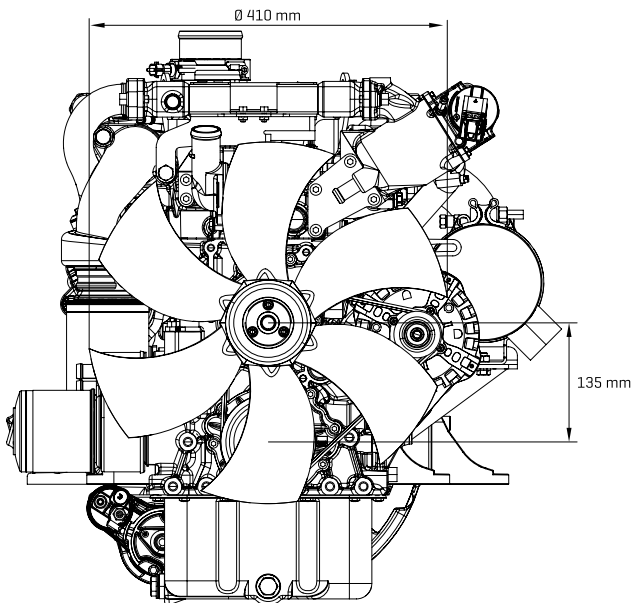
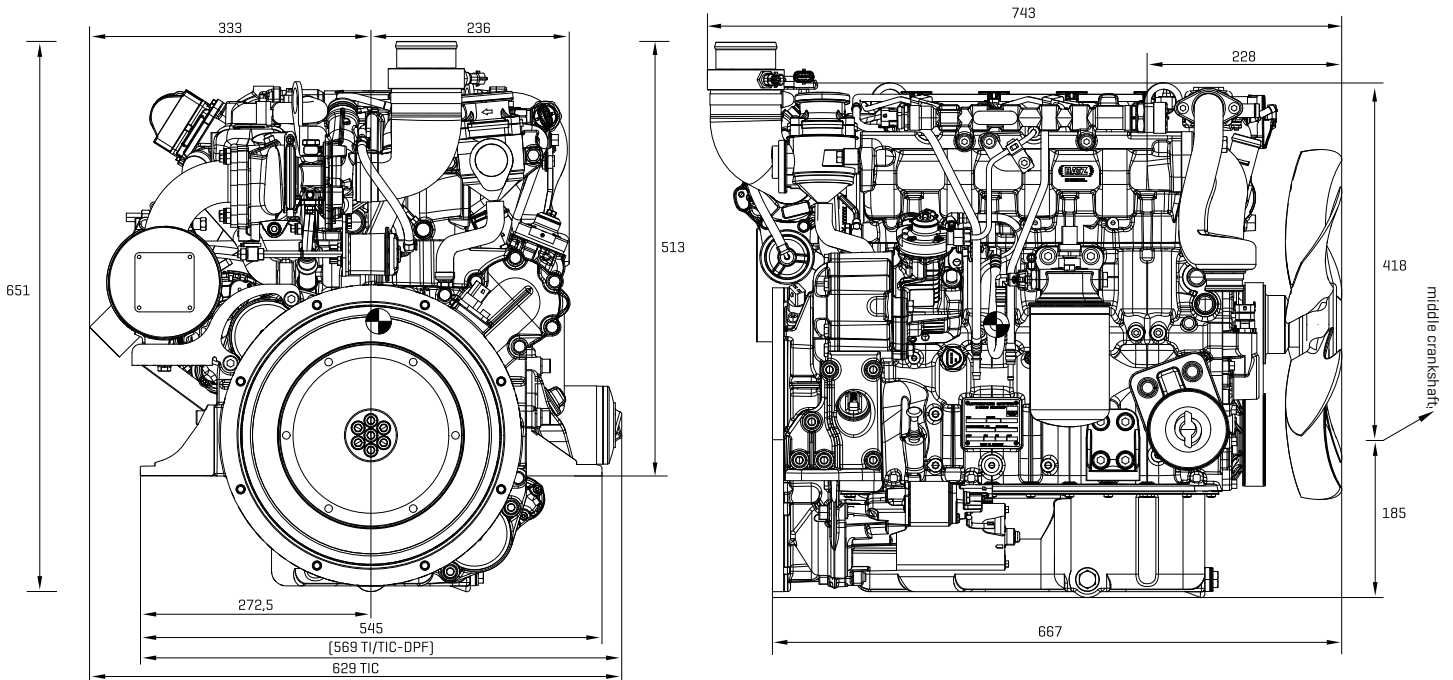

Diesel particulate filter (DPF)

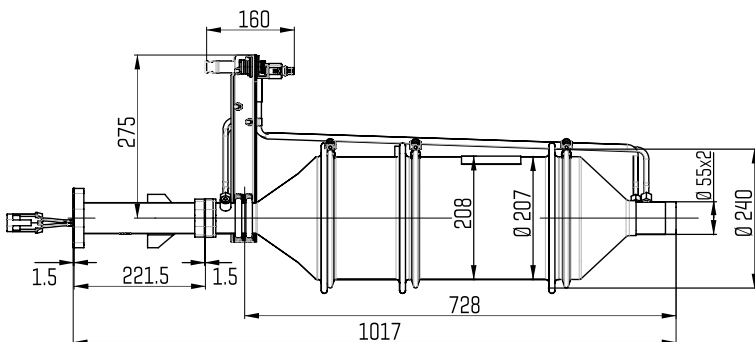

Spread at box dimensions ± 3 mm due to tolerance.
 Drawings with detail and connection dimensions as PDF resp. DXF can be found at www.HATZ-DIESEL.com.

Motorenfabrik Hatz GmbH & Co. KG
Ernst-Hatz-Str. 16
94099 Ruhstorf a.d. Rott
Germany
Phone +49 8531 319-0
Fax +49 8531 319-418
marketing@hatz-diesel.de
www.hatz-diesel.com



CREATING POWER SOLUTIONS.

702 528 31 EN -09.15-1 Printed in Germany
Modifications, which serve technical
improvement, are reserved.